



**CBSE Sample  
Question Paper  
(2023-24)**

# SCIENCE

**Class-X**

# Solved

*(with Marking Scheme)*

# CBSE SAMPLE QUESTION PAPER (2023-24) with MARKING SCHEME

## Science

Time Allowed : 3 Hours

CLASS-X

Maximum Marks : 80

### General Instructions :

1. This question paper consists of 39 questions in 5 sections.
2. All questions are compulsory. However, an internal choice is provided in some questions. A student is expected to attempt only one of these questions.
3. Section A consists of 20 objective type questions carrying 1 mark each.
4. Section B consists of 6 Very Short questions carrying 02 marks each. Answers to these questions should be in the range of 30 to 50 words.
5. Section C consists of 7 Short Answer type questions carrying 03 marks each. Answers to these questions should be in the range of 50 to 80 words.
6. Section D consists of 3 Long Answer type questions carrying 05 marks each. Answer to these questions should be in the range of 80 to 120 words.
7. Section E consists of 3 source-based/case-based units of assessment of 04 marks each with sub-parts.

### SECTION 'A'

Select and write the most appropriate option out of the four options given for each of the questions 1-20. There is no negative mark for incorrect response.

1. Identify the product which represents the solid state in the above reaction. 1

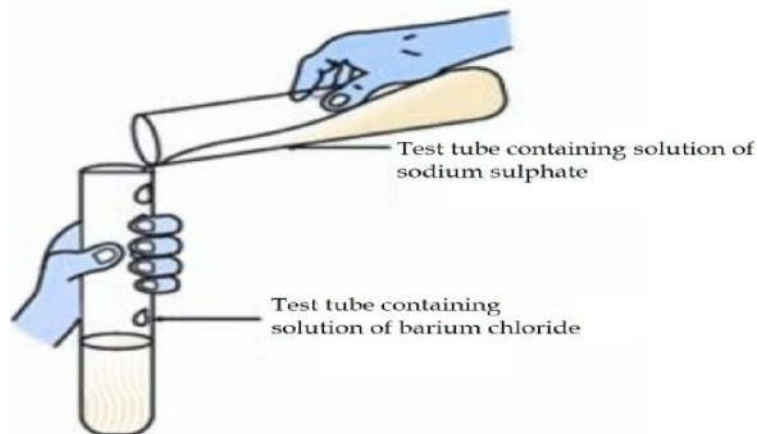

- (a) Barium chloride (b) Barium sulphate  
(c) Sodium chloride (d) Sodium sulphate

Ans. (b) Barium sulphate

2. The colour of the solution observed after 30 minutes of placing zinc metal to copper sulphate solution is 1

- (a) Blue (b) Colourless (c) Dirty green (d) Reddish Brown

Ans. (b) Colourless

3. Mild non-corrosive basic salt is

- (a)  $\text{Ca}(\text{OH})_2$  (b) NaCl (c) NaOH (d)  $\text{NaHCO}_3$

Ans. (d)  $\text{NaHCO}_3$

4. On adding dilute sulphuric acid to a test tube containing a metal 'X', a colourless gas is produced when a burning match stick is brought near it. Which of the following correctly represents metal 'X'? 1

- (a) Sodium (b) Zinc (c) Copper (d) Silver

Ans. (a) Sodium

5. Which one of the following correctly represents sodium oxide? 1

- (a)  $\text{Na}^{+2} 2 \left[ \begin{array}{ccc} \times & \times & \times \\ \times & \text{O} & \times \\ \times & \times & \times \end{array} \right]^{-2}$                       (b)  $2\text{Na}^+ \left[ \begin{array}{ccc} \times & \times & \times \\ \times & \text{O} & \times \\ \times & \times & \times \end{array} \right]^{-2}$
- (c)  $2\text{Na}^+ 2 \left[ \begin{array}{ccc} \times & \times & \times \\ \times & \text{O} & \times \\ \times & \times & \times \end{array} \right]^{-1}$                       (d)  $2\text{Na}^{+1} \left[ \begin{array}{ccc} \times & \times & \times \\ \times & \text{O} & \times \\ \times & \times & \times \end{array} \right]^{-2}$

Ans. (b)  $2\text{Na}^+ \left[ \begin{array}{ccc} \times & \times & \times \\ \times & \text{O} & \times \\ \times & \times & \times \end{array} \right]^{-2}$

6. An element with atomic number \_\_\_\_\_ will form a basic oxide. 1

- (a) 7 (2,5)                      (b) 17 (2,8,7)                      (c) 14 (2,8,4)                      (d) 11 (2,8,1)

Ans. (d) 11 (2,8,1)

7. An element 'M' has 50% of the electrons filled in the 3rd shell as in the 2nd shell. The atomic number of 'M' is : 1

- (a) 10                      (b) 12                      (c) 14                      (d) 18

Ans. (c) 14

8. Generally food is broken and absorbed within the body of organisms. In which of the following organisms is it done outside the body ? 1

- (a) *Amoeba*                      (b) Mushroom                      (c) *Paramecium*                      (d) Lice

Ans. (b) Mushroom

9. Receptors are usually located in sense organs. Gustatory receptors are present in 1

- (a) tongue                      (b) nose                      (c) eye                      (d) ear

Ans. (a) tongue

10. A farmer wants to grow banana plants genetically similar enough to the plants already available in his field. Which one of the following methods would you suggest for this purpose? 1

- (a) Regeneration                      (b) Budding  
(c) Vegetative propagation                      (d) Sexual reproduction

Ans. (c) Vegetative propagation

11. Height of a plant is regulated by : 1

- (a) DNA which is directly influenced by growth hormone.  
(b) Genes which regulate the proteins directly.  
(c) Growth hormones under the influence of the enzymes coded by a gene.  
(d) Growth hormones directly under the influence a gene.

Ans. (c) Growth hormones under the influence of the enzymes coded by a gene.

12. A sportsman, after a long break of his routine exercise, suffered muscular cramps during a heavy exercise session. This happened due to : 1

- (a) lack of carbon dioxide and formation of pyruvate.  
(b) presence of oxygen and formation of ethanol.  
(c) lack of oxygen and formation of lactic acid.  
(d) lack of oxygen and formation of carbon dioxide.

Ans. (c) lack of oxygen and formation of lactic acid.

13. An object is placed in front of a convex mirror. Its image is formed : 1

- (a) at a distance equal to the object distance in front of the mirror.  
(b) at twice the distance of the object in front of the mirror.  
(c) half the distance of the object in front of the mirror.  
(d) behind the mirror and its position varies according to the object distance.

Ans. (d) behind the mirror and its position varies according to the object distance.

**14. When light enters the atmosphere it strikes on extremely fine particles, which deflect the rays of light in all possible directions, This is due to :** **1**

- (a) reflection of light (b) atmospheric refraction  
(c) scattering of light (d) dispersion of light

**Ans.** (c) scattering of light

**15. In 1987, an agreement was formulated by the United Nations Environment Programme (UNEP) to freeze the production of “X” to prevent depletion of “Y”. “X” and “Y” respectively referred here are :** **1**

- (a) Ozone; CFCs (b) CFCs; rays UV  
(c) CFCs; Ozone (d) UV rays; Diatomic oxygen

**Ans.** (c) CFCs; Ozone

**16. Which of the following features relates to biodegradable substances?** **1**

- (a) Broken down by biological processes (b) Remain inert  
(c) Persist in environment for long time (d) May harm the ecosystem

**Ans.** (a) Broken down by biological processes

*Question No. 17 to 20 consist of two statements — Assertion (A) and Reason (R). Answer these questions selecting the appropriate option given below :*

- (a) Both A and R are true, and R is the correct explanation of A.  
(b) Both A and R are true, and R is not the correct explanation of A.  
(c) A is true but R is false.  
(d) A is false but R is true.

**17. Assertion :** Rusting of Iron is endothermic in nature.

**Reason :** As the reaction is slow, the release of heat is barely evident. **1**

**Ans.** (d) A is false but R is true.

**18. Assertion :** Probability of survival of an organism produced through sexual reproduction is more than that of organism produced through asexual mode.

**Reason :** Variations provide advantages to individuals for survival. **1**

**Ans.** (a) Both A and R are true, and R is the correct explanation of A.

**19. Assertion :** A compass needle is placed near a current carrying wire. The deflection of the compass needle decreases when the magnitude of the current in the wire is increased.

**Reason :** The strength of a magnetic field at a point near the conductor increases on increasing the current. **1**

**Ans.** (d) A is false but R is true.

**20. Assertion :** Biodegradable substances result in the formation of compost and natural replenishment.

**Reason :** It is due to breakdown of complex inorganic substances into simple organic substances. **1**

**Ans.** (c) A is true but R is false.

## SECTION ‘B’

*Question No. 21 to 26 are Very Short Answer Questions.*

**21. Dil. HCl is added to Zn granules.” How will you prove that chemical change has taken place here? Support your response with two arguments.** **2**

**Ans.** Response with any of the given two arguments. **[1+1]**

- | Bubbles of gas/Evolution of gas
- | Change in colour (Zn — silvery grey to black)
- | Change in temperature

**22. State the post-fertilisation changes that lead to fruit formation in plants. 2**

**Ans.** After fertilisation, the zygote divides several times to form an embryo within the ovule.

- | The ovule develops a tough coat and is gradually converted into a seed.
- | The ovary grows rapidly and ripens to form a fruit.
- | The petals, sepals, stamens, style and stigma may shrivel and fall off. [0.5×4=2]

**23. What is the purpose of making urine in the human body? Name the organs that stores and releases the urine. 2**

**Ans.** To filter out nitrogenous waste products like urea and uric acid [0.5]  
from the blood [0.5]  
in humans.

Organ for storage : Urinary Bladder [0.5]

Organ for release: Urethra [0.5]

*Or*

**Why do arteries have thick and elastic walls whereas veins have valves? 2**

**Ans.** The blood emerges from the heart under high pressure and flows through arteries. Hence, to bear this pressure the arteries have thick and elastic walls. [1]

Veins have valves to ensure that the blood flows in one direction only. [1]

**24. The refractive indices of three media are given below : 2**

Medium	Refractive Index
A	1.6
B	1.8
C	1.5

**A ray of light is travelling from A to B and another ray is travelling from B to C.**

**(a) In which of the two cases the refracted ray bends towards the normal?**

**(b) In which case does the speed of light increase in the second medium? Give reasons for your answer.**

**Ans.** (a) When light travels from an optically rarer medium to an optically denser medium it moves towards the normal. Since  $n_B > n_A$  hence the light ray will bend towards the normal on passing from medium A to B. [0.5 + 0.5]

(b) The speed of the light will increase when the light travels from B to C, Since  $n_C < n_B$  and  $v = \left(\frac{c}{n}\right)$ , the speed of light ray will increase in the second medium. [0.5 + 0.5]

**25. A piece of wire of resistance R is cut into three equal parts. These parts are then connected in parallel. If the equivalent resistance of this parallel combination is R<sub>1</sub>, what is the value of the ratio R<sub>1</sub> : R ? 2**

**Ans.** Resistance of each part is  $\frac{R}{3}\Omega$  (as resistance is proportional to the length of the wire.) [0.5]

$$\frac{1}{R_1} = \frac{3}{R} + \frac{3}{R} + \frac{3}{R} = \frac{9}{R} \quad [1]$$

$$\therefore R_1 = \frac{R}{9} \quad \therefore \frac{R_1}{R} = \frac{1}{9} \quad [0.5]$$

Or

Refer to the image below and state how the magnetic field pattern indicates regions where the magnetic field is stronger outside the magnet? What happens to the magnetic field when the current in the circuit is reversed?

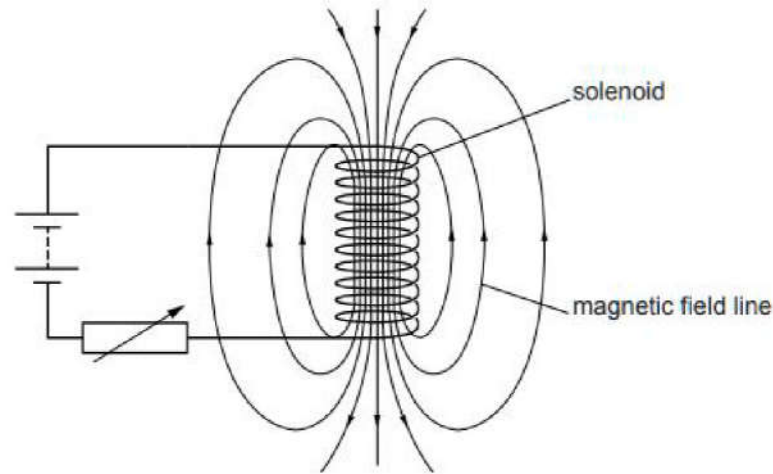

**Ans.** The magnetic field strength is more in the region where the field lines are crowded. This means the field strength is maximum near the poles and it reduces as we go away from the poles. [0.5 + 0.5]

The direction of the magnetic field is also reversed. [1]

26. Study the food chain given below and answer the questions that follow : 2

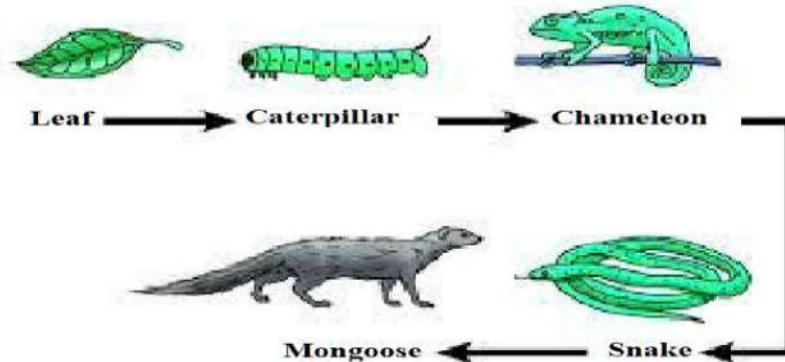

(a) If the amount of energy available at the third trophic level is 100 joules, then how much energy will be available at the producer level? Justify your answer.

(b) Is it possible to have 2 more trophic levels in this food chain just before the fourth trophic level? Justify your answer. 2

**Ans.** (a) 10000J because only 10 % of energy is available for the next trophic level.

(b) No, since the loss of energy at each step is so great that very little usable energy will remain after 4 trophic levels.

### SECTION 'C'

Question No. 27 to 33 are Short Answer Questions.

27. The given reaction shows one of the processes to extract the metals like Iron and Manganese. 3



(a) Give reason why the above reaction is known as a thermite reaction.

(b) Identify the substance oxidised and reduced in the above reaction.

(c) Give a reason why Aluminium is preferably used in thermite reactions.

**Ans.** (a) The above reaction is known as a thermite reaction as the reaction is highly exothermic reaction.

*Or*

the metal (Mn/Fe) obtained will be in molten/liquid state. [1]

(b) Substance oxidised — Al(s) [0.5]

Substance reduced — MnO<sub>2</sub>(s) [0.5]

(c) Aluminium is preferably used in thermite reactions as it is placed above Fe and Mn in reactivity series of metals. [1]

*Or*

Al is more reactive than Fe/Mn

- 28. An element 'M' with electronic configuration 2 8 3 combines separately with Cl<sup>-</sup>, SO<sub>4</sub><sup>-2</sup> anions. Write the chemical formulae of the compounds formed. Predict with the suitable reason the nature of the bond formed by element 'M' in general. How will the electrical conductivity of the compounds formed vary with respect to 'M' ?** 3

**Ans.** MCl<sub>3</sub>; M<sub>2</sub>(SO<sub>4</sub>)<sub>3</sub> [1]

M in general forms Ionic bond. It can acquire a stable electronic configuration of neon (2, 8) by losing its three valence electrons to form M<sup>3+</sup> cation. [1]

Compounds formed will conduct electricity in liquid/molten state but not in solid state in contrast to 'M'. [1]

*Or*

**A reddish-brown metal 'X', when heated in air, gives a black compound 'Y', which when heated in presence of H<sub>2</sub> gas gives 'X' back. 'X' is refined by the process of electrolysis; this refined form of 'X' is used in electrical wiring. Identify 'X' and 'Y'. Draw a well-labeled diagram to represent the process of refining 'X'.** 3

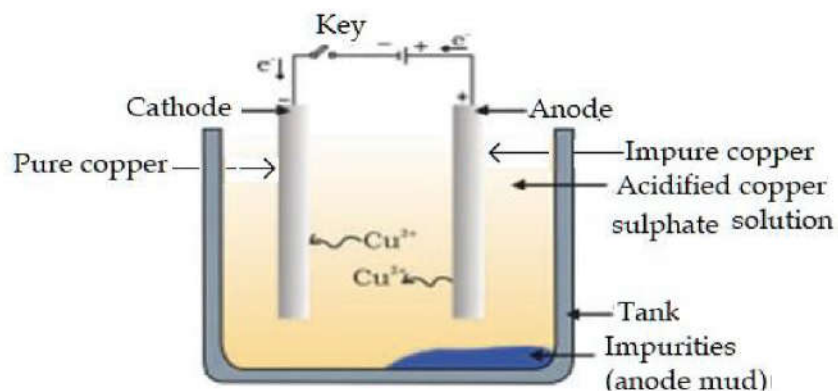

**Ans.** (a) 'X' — Copper/Cu and 'Y' — CuO [1]

(b) Diagram to represent the process of refining of 'X' [2]

- 29. We are advised to take iodised salt in our diet by doctors. Justify its importance in our body.** 3

**Ans.** Iodine is essential for the synthesis of thyroxin hormone.

┆ Thyroxin regulates carbohydrate, protein and fat metabolism in the body.

┆ Thyroxin provide best balance for growth in the body.

- 30. What is the probability of a girl or a boy being born in a family? Justify your answer.** 3

**Ans.** There are 50% chances that a girl may be born and 50% chances that a boy may be born. [1]

It can be explained as follows :

Most human chromosomes have a maternal copy and a paternal copy. We have 22 such chromosomes. One pair of chromosomes called sex chromosomes is odd in not always being

a perfect pair. Women have a perfect pair of sex chromosomes, both called X. (XX) [0.5]

But men have a mismatched pair of sex chromosomes in which one is normal sized — X chromosome while the other is a short one called Y chromosome. (XY) [0.5]

A child receives one chromosome from mother which is essentially X chromosome. [0.5]

A child who inherits an X chromosome from her father will be a girl, and one who inherits a Y chromosome from him will be a boy. [0.5]

31. (i) Explain why the refractive index of any material with respect to air is always greater 1.

(ii) In the figure below a light ray travels from air into the semi-circular plastic block. Give a reason why the ray does not deviate at the semi-circular boundary of the plastic block.

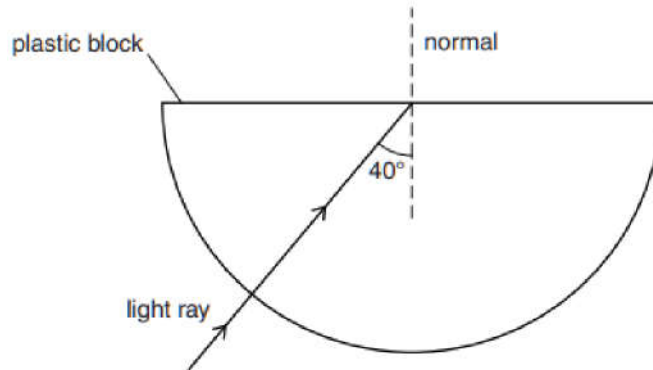

(iii) Complete the ray diagram of the above scenario when the light ray comes out of the plastic block from the top flat end. 1+1+1

Ans. (i) The refractive index of a medium with respect to air is given by

$$\frac{\text{Speed of light in air}}{\text{Speed of light in the medium}}$$

Since speed of light in the medium is always less than the speed of light in air, hence the above ratio is always greater than 1. [0.5+0.5]

(ii) The ray of light is undergoing normal incidence at the air-plastic block interface. And for normal incidence there is no deviation. [1]

(iii) [0.5+0.5]

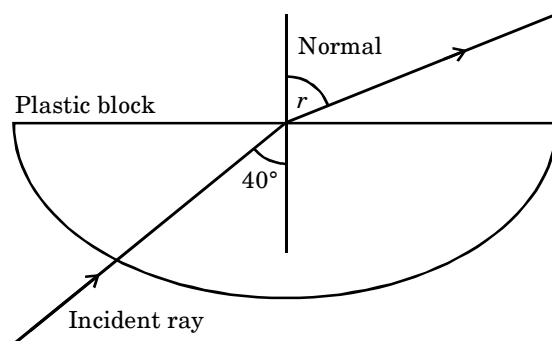

(Credit arrows, refracted ray moving away from normal)

32. (i) State the law that explains the heating effect of current with respect to the measurable properties in an electrical circuit.

(ii) List the factors on which the resistance of a conductor depends. 2+1

Ans. (i) Joules law of heating states that the heat dissipated across a resistor is directly proportional to [0.5 for naming only]



- (a) the square of the current flowing through it  
 (b) The resistance of the conductor  
 (c) duration of flow of current. [1.5]

$$H = I^2 R t \text{ (alternative answer)}$$

- (i) Resistance of a conductor depends on  
 (a) the length of the conductor  
 (b) the area of the cross section  
 (c) nature of material  
 (d) temperature of the conductor (Any two should fetch full marks) [0.5+0.5]

**33. Anannya responded to the question : Why do electrical appliances with metallic bodies are connected to the mains through a three pin plug, whereas an electric bulb can be connected with a two pin plug? She wrote : Three pin connections reduce heating of connecting wires.**

**(j) Is her answer correct or incorrect? Justify.**

**(k) What is the function of a fuse in a domestic circuit? 2+1**

**Ans.** (j) Anannya's answer is wrong. Electrical appliances with metallic bodies need an earth wire which provides a low resistance conducting path to the flow of current, in case there is an accidental leakage of current through the conducting body of the appliances.

[1+1]

- (k) An electrical fuse is a safety device that operates to provide protection against the overflow of current in an electrical circuit. An important component of an electrical fuse is a metal wire or strip that melts when excess current flows through it. [1]

### SECTION 'D'

*Question No. 34 to 36 are Long Answer Questions.*

**34. (a) Rehmat classified the reaction between Methane and Chlorine in presence of sunlight as a substitution reaction. Support Rehmat's view with suitable justification and illustrate the reaction with the help of a balanced chemical equation.**

**(b) Chlorine gas was prepared using electrolysis of brine solution. Write the chemical equation to represent the change. Identify the other products formed in the process and give one application of each. 5**

**Ans.** (a) Rehmat's observation is correct as the hydrogen atoms are substituted by hetero atom *i.e.*, Cl



*Or*

Any other relevant equation in the chain reaction

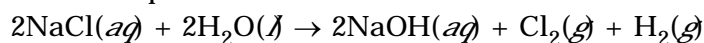

*Or*

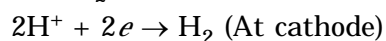
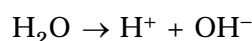
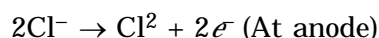

(b) Sodium hydroxide/NaOH/Caustic soda [1]  
 Hydrogen  $\frac{1}{2}$

Uses : (any one each) [1]

Sodium hydroxide/NaOH/Caustic soda

i. Degreasing of metals

- | Preparation of soaps and detergents
- | Paper making
- | Artificial fibres

Hydrogen

- | Fuels
- | Margarine
- | Manufacture of ammonia for fertilizers

*Or*

**Raina while doing certain reactions observed that heating of substance 'X' with vinegar like smell with a substance 'Y' (which is used as an industrial solvent) in presence of conc. Sulphuric acid on a water bath gives a sweet-smelling liquid 'Z' having molecular formula  $C_4H_8O_2$ . When heated with caustic soda (NaOH), 'Z' gives back the sodium salt of and the compound 'Y'.**

**Identify 'X', 'Y', and 'Z'. Illustrate the changes with the help of suitable chemical equations.**

**Ans.** X — Ethanoic acid/ acetic acid/ $CH_3COOH$

Y — Ethanol/Ethyl alcohol/ $C_2H_5OH$

Z — Ethyl ethanoate/Ester —  $CH_3COOC_2H_5$  [1×3]

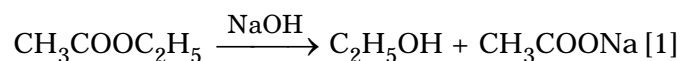
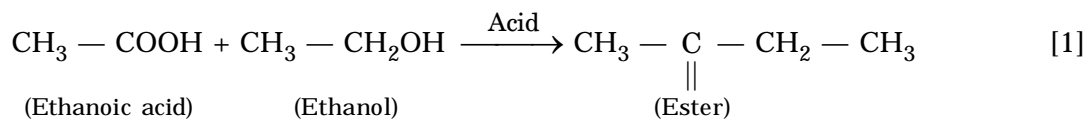

**35. Given below are certain situations. Analyze and describe its possible impact on a person :**

- (a) Testes of a male boy are not able to descend into scrotum during his embryonic development.
- (b) Vas deferens of a man is plugged.
- (c) Prostate and seminal vesicles are not functional.
- (d) Egg is not fertilised in a human female.
- (e) Placenta does not attach to the uterus optimally. 5

**Ans.** (a) Sperm formation will be adversely affected because it requires a lower temperature than the body temperature.

- (b) Vas deferens is a passage for transfer of sperms, so sperms will not be transferred further.
- (c) When prostate and seminal vesicles are not functional, they will not add secretions for nourishment and medium for the transport of sperms.
- (d) When an egg is not fertilised in a human female, it lives for about one day. Then, the thickened lining of the uterus breaks leading to discharge of blood and mucus along with the unfertilised egg. This is called menstruation.
- (e) Nutrition and oxygen will not be provided to the growing embryo affecting its growth, which could have serious implications as well.

*Or*

- (a) A doctor has advised Sameer to reduce sugar intake in his diet and do regular exercise after checking his blood test reports. Which disease do you think Sameer is suffering from ? Name the hormone responsible for this disease and the organ producing the hormone.
- (b) Which hormone is present in the areas of rapid cell division in a plant and which hormone inhibits the growth? 3+2

- Ans.** (a) | Sameer is suffering from diabetes  
 | Insulin  
 | Pancreas  
 (b) | Cytokinins  
 | Abscisic Acid

36.

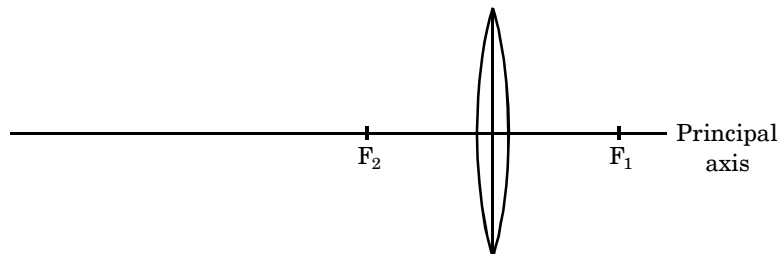

The above image shows a thin lens of focal length 5 m.

- (i) What is the kind of lens shown in the above figure?  
 (ii) If a real inverted image is to be formed by this lens at a distance of 7 m from the pole, then show with calculation where should the object be placed?  
 (iii) Draw a neatly labelled diagram of the image formation mentioned in (ii).

1+2+2

**Ans.** (i) Convex lens

[1]

$$(ii) \frac{1}{f} = \frac{1}{v} - \frac{1}{u}$$

In this case,  $v = 7$  m and  $f = 5$  m.

Putting the values in the equation we get

$$\frac{1}{5} = \frac{1}{7} - \frac{1}{u}$$

$$\frac{1}{u} = \frac{1}{7} - \frac{1}{5} = \frac{5-7}{35} = \frac{-2}{35}$$

$$u = -\frac{35}{2} = -17.5 \text{ m.}$$

The object will be placed 17.5 m on the left of the convex lens.

[0.5 × 4]

(iii)

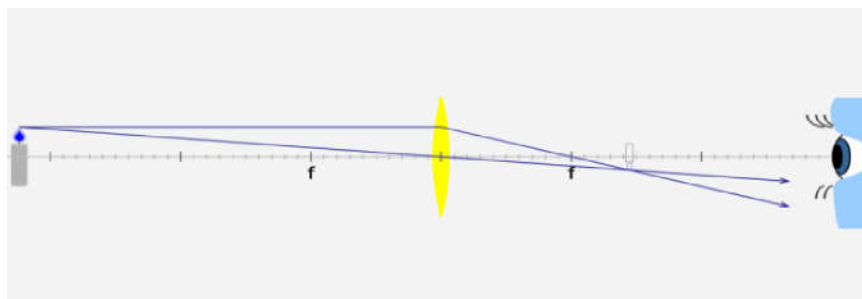

(two rays, arrows, object placed beyond  $2f$  on the left)

[2]

Or

A 10 cm long pencil is placed 5 cm in front of a concave mirror having a radius of curvature of 40 cm.

- (i) Determine the position of the image formed by this mirror.  
 (ii) What is the size of the image?  
 (iii) Draw a ray diagram to show the formation of the image as mentioned in the part (i).

2+1+2

Ans.  $\frac{1}{f} = \frac{1}{v} + \frac{1}{u}$  where  $u = -5$  cm,  $f = \frac{r}{2} = -20$  cm

$$-\frac{1}{20} = \frac{1}{v} - \frac{1}{5}$$

$$\frac{1}{v} = -\frac{1}{20} + \frac{1}{5} = \frac{-1+4}{20} = \frac{3}{20}$$

[0.5 × 4]

$$v = \frac{20}{3} = 6.67 \text{ cm}$$

The image is obtained at 6.67 m behind the mirror.

$$(i) m = \frac{h_2}{h_1} = -\frac{v}{u} = \frac{3}{5} = \frac{4}{3}$$

[0.5+0.5]

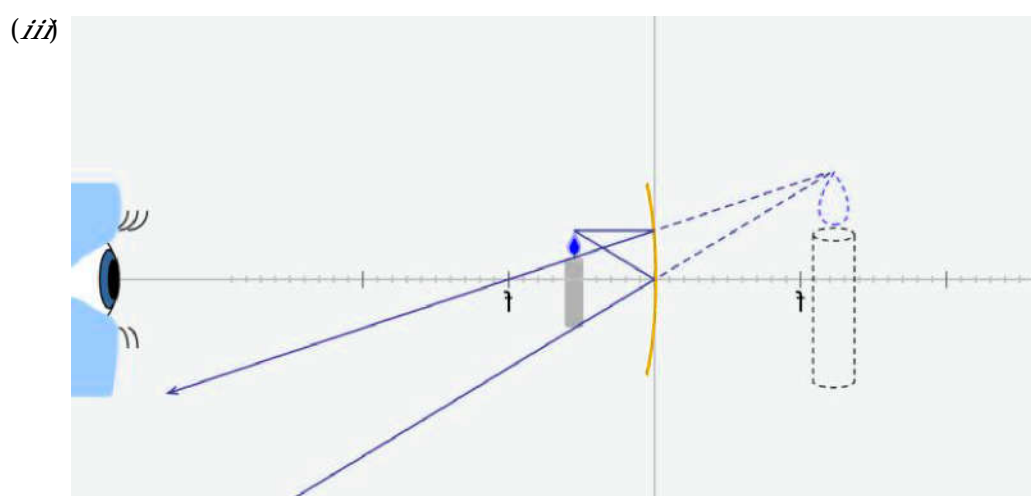

(two rays, arrows, object placed between pole and the focus)

[2]

### SECTION 'F'

Question No. 37 to 39 are case-based/data-based questions with 2 to 3 short sub-parts. Internal choice is provided in one of these sub-parts.

37. The table given below shows the hints given by the quiz master in a quiz. 4

S. No.	HINT
(i)	Substance 'C' is used as a preservative.
(ii)	'C' has two carbon atoms; 'C' is obtained by the reaction of 'A' in presence of alkaline Potassium permanganate followed by acidification.
(iii)	Misuse of 'A' in industries is prevented by adding Methanol, Benzene, and pyridine to 'A'.
(iv)	'F' is formed on heating 'A' in presence of conc Sulphuric acid.
(v)	'F' reacts with Hydrogen gas in presence of Nickel and Palladium catalyst.

Based on the above hints answer the following questions

(a) Give the IUPAC names of A and F.

(b) Illustrate with the help of chemical equations the changes taking place.

(A → C and A → F)

4

**Ans.** (a) A — Ethanol; F — Ethene [2]

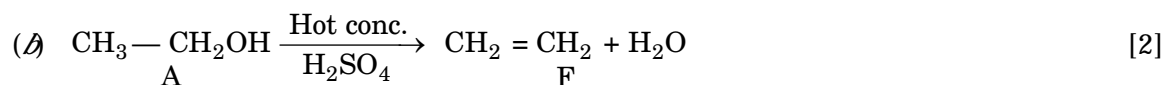
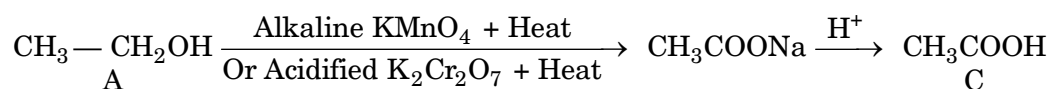

*Or*

**Name the chemical reactions which occur in steps 2 and 5. Identify the compounds formed in these steps if 'A' is replaced with its next homologue. 4**

**Ans.** Oxidation, Addition/Hydrogenation

Propanol, Propene

**38. Figures (a) to (d) given below represent the type of ear lobes present in a family consisting of 2 children — Rahul, Nisha and their parents. 4**



a) Rahul's Father



b) Rahul



c) Rahul's Mother



d) Rahul's sister Nisha

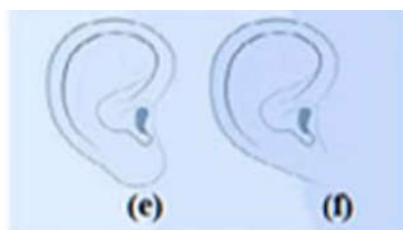

**Type of ear lobes**

Excited by his observation of different types of ear lobes present in his family, Rahul conducted a survey of the type of ear lobes found {Figure (e) and (f)} in his classmates. He found two types of ear lobes in his classmates as per the frequency given below :

Sex	Free	Attached
Male	36	14
Female	31	19

On the basis of above data answer the following questions.

- (a) Which of the two characteristics — 'free ear lobe' or 'attached ear lobe' appears to be dominant in this case? Why?
- (b) Is the inheritance of the free ear lobe linked with sex of the individual? Give reason for your answer.
- (c) What type of ear lobe is present in father, mother, Rahul and his sister Nisha? Write the genetic constitution of each of these family members which explains the inheritance of this character in this family?

(Gene for Free ear lobe is represented by F and gene for attached ear lobe is represented by f for writing the genetic constitution).

**Ans.** (a) Free ear lobe is dominant because it is found in a large majority of the population. (1)

(b) No. It is not sex linked. As per the data of the family as well as the class, it is indicated that free ear lobe is present in males as well as in females. (1)

(c) Father — Ff (free ear lobe), Mother — Ff (free ear lobe), Rahul — ff (attached ear lobe) and Nisha — Ff (free ear lobe) (½ × 4 = 2)

Or

**Suresh’s parents have attached ear lobes. What type of ear lobe can be seen in Suresh and his sister Siya? Explain by giving the genetic composition of all. 4**

**Ans.** Suresh’s father — ff (attached ear lobe), mother — ff (attached ear lobe), Suresh — ff (attached ear lobe), Siya — ff (attached ear lobe). If both parents have recessive character, then all the children can have recessive character only.

- 39. Vinita and Ahmed demonstrated a circuit that operates the two headlights and the two sidelights of a car, in their school exhibition. Based on their demonstrated circuit, answer the following questions.**

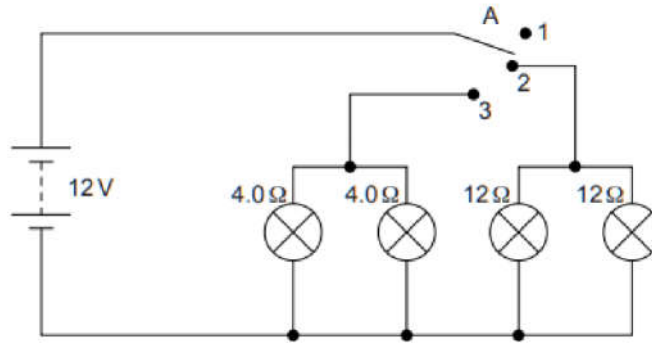

**(i) State what happens when switch A is connected to**

**(a) Position 2**

**(b) Position 3**

**(ii) Find the potential difference across each lamp when lit.**

**(iii) Calculate the current**

**1+1+2**

**(a) in each 12 Ω lamp when lit.**

**(b) In each 4 Ω lamp when lit.**

**Ans. (i) 12 Ω lamps (only) on.**

**(a) 4 Ω lamps (only) on**

**[0.5+0.5]**

**(ii) 12 V for both sets of lamps and all of them are in parallel.**

**[1]**

**(iii) 12 Ω lamps are on when the wire is connected to position 2.**

Voltage across both 12 Ω lamps = 12 V.

$V = IR$  (Ohm’s law).

$$I = \frac{V}{R} = \frac{12}{12} = 1A.$$

**[1]**

4 Ω lamps are on when the wire is connected to position 3.

Voltage across both 4 Ω lamps = 12 V.

$V = IR$  (Ohm’s law).

$$I = \frac{V}{R} = \frac{12}{4} = 3A.$$

**[1]**

Or

**(iv) Show, with calculations, which type of lamp, 4.0 Ω or 12 Ω, has the higher power.**

**Ans.**  $P = \frac{V^2}{R}$

All lamps are in parallel and hence same V for all lamps.

For 4 Ω lamps  $\rightarrow P = \frac{12 \times 12}{4} = 36 \text{ W}$

For 12 Ω lamps  $\rightarrow P = \frac{12 \times 12}{12} = 12 \text{ W}$

Hence 4 Ω lamps will have higher power.

**[0.5 × 4]**